

GLE is a flame proof bypass type tunable laser gas analyzer for industrial on-line analysis and environmental on-line monitoring, especially suitable for harsh working condition such as high temperature, high humidity, high dust, high pressure, and for small pipes where in-situ analyzer is not applicable. The transmitter and receiver are installed on a back board. The analyzer contains auto purge function which greatly reduces maintenance cost.

Gas Path

Extracted by a jet pump, the sample gas is filtered (get rid of dust), heated (avoid condensation), cooled (for high temperature conduction), then reach analyze module to be measured. Shutting off ball valve and analyze module, the analyzer carries out a calibration to ensure accuracy. Shutting off ball valve and opening back-flush valve ensures gas path unblocked.

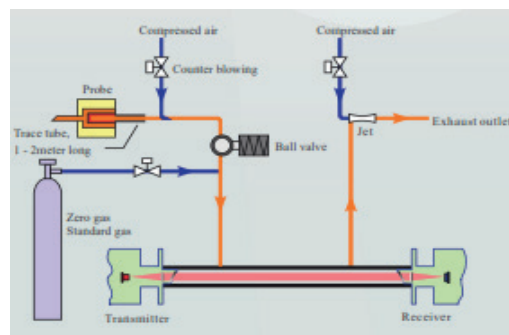

Configuration of GLE is different in different situations. For example, for high pressure situation, a relief valve is added and air pump is removed. For high temperature situation, the heat tracing temperature is higher.

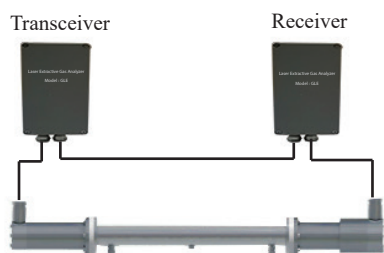

Features

- Suitable for harsh working conditions such as high temperature, high humidity, high dust, high pressure and small pipes where are not suitable for Insitu measurement
- Single Line Spectrum technology free from interference of background gas
- Automatic calibration, and backblow
- Integrated structure design, high reliability and stability
- Innovative Hall button design, high sensitivity and easy operation

Specification Parameter

Linearity Error	≤ ± 1%FS
Repeatability	≤ 1%
Span Drift	≤ ± 1%FS / 6 months
Zero Drift	≤ ± 1%FS/ 6 months
Maintenance Cycle	≤ 2 times/year., clean optical window
Calibration Cycle	≤ 2 times/year
Type of Protection	ExdIICT6 Gb
Enclosure Rating	IP66
Preheating Time	≤ 15 min
Response Time (T ₉₀)	2 ≤ 30s (Related to the working condition)
Analogue Output	2 x 4-20mA output (Isolation, max load 750Ω)
Analogue Input	2 x 4-20mA input (Temp, & Press. compensation)
Digital Output	RS485 / RS232 / GPRS
Relay Contact	3 (24V, 1A)
Power Supply	24 VDC, <20W (without pretreatment system components)
Pressure Gas	0.3 MPa ~ 0.8 MPa industrial nitrogen, purification instrument air, etc
Ambient Temperature	-20°C ~ +60°C
Installation Way	By-pass type Installation